

使用范围:

- I YT24 型气腿式凿岩机最适用于在中硬或坚硬($f=8 \sim 18$)岩石上钻凿水平和倾斜方向炮孔,是矿山、铁路、交通、水利建设等石方工程中的重要机具。
- I 本机可与 FT140B 型或 FT140BD 型气腿及有透明壳体的 FY200B 型注油器配套使用,也可装在钻车或钻架上工作。

Introduction:

- I YT24 Air-leg Rock Drill, an important tool for rock drilling operations in mines, railway, communication and water conservancy projects, etc., is most suitable for making horizontal and inclined blastholes in medium-hard and hard rocks with a hardness of $f8 \sim 18$.
- I May be used together with FT140B or FT140BD Air-leg and FY200B Line Oiler with transparent casing. The tool can also be mounted on a rig or a wagon.

YT24 型凿岩机技术规格 YT24 Specifications:

机重	Weight	kg	24
长×宽×高	L×W×H	mm	678×228×184
工作气压	Air pressure	MPa	0.63
凿岩机耗气量*	Air consumption*	L/s	≤67
凿岩频率	Impact frequency	Hz	≥31
气管内径	Air hose size	mm	19
水管内径	Water hose size	mm	13
钻孔直径	Bore dia.	mm	Φ34~Φ42
钻孔深度	Drilling depth	m	5
钎尾规格 (六方对边×长度)	Shank size(Hex.×L)	mm	22*108±1

气腿技术规格 Air-leg Specifications

气腿型号	Model		FT140B	FT140BD
气腿长度	Length	mm	1687	1400
推进行程	Feed length	mm	1250	965
重量	Weight	kg	15.6	13.9

FY200B 型注油器技术规格 FY200B Line Oiler Specifications

贮油量度	Capacity	ml	200
重量	Weight	kg	1.02

结构特点：

- l 操作机构集中、启动灵活、气水联动、使用方便、维修简易；
- l 噪声低、振动小、节能高效、零件寿命长、通用率高、可靠性好。

Features:

- l Grouped control mechanism, quick of start up, with “air-on, water-on, air-off, water-off” mechanism, easy operation and maintenance.
- l Low noise, small vibration, energy-saving and efficient, highly interchangeable parts with long service life, reliable performance.

使用与维修：

除必须遵循一般凿岩作业的技术安全规程外，还应特别注意：

- l 螺旋母与活塞是左旋螺纹连接，拆装时要注意旋转方向；
- l 凿岩机通气、水前，细致检查钢丝卡环（32）（36）是否完整正确地卡在柄体（30）半圆槽内，并随时注意其磨损情况，磨损或失效后及时更换，以免通气、通水时，气管弯头（55）和水管弯头（58）崩出；
- l 机器开动前，要将 FY200B 型注油器注满润滑油，严禁无润滑油作业（推荐选用 GB443-84 所规定的 N46，N22 润滑油）；
- l 机器工作结束，应先关闭水管，再轻运转片刻，吹净机内残余水滴，防止零件锈蚀。
- l 经常使用的机器，应注意定期保养和维护。保持机内清洁，注意

更换损坏和失效的零件，消除故障隐患。

Operation & maintenance:

Besides observance of the general safety precautions for rock drilling operations, particular attention should be paid to the following:

- I The rifle nut and the piston are matched with left-handed threads. Be careful with the direction of rotation during assembling and disassembling.
- I When connecting the drill to the air and water supplies, check carefully if the wire clips (32)(36) are entirely and correctly set in the respective semi-circular grooves of the backhead (30). Check frequently the wear on the clips and timely replace the worn-out or broken one or broken one to avoid the shooting out of the swivel(55)(58) or the connector when the air or water is on.
- I Before operation, fill the line oiler with lubrication oil up to the required level. The drill should not be run without proper lubrication (recommended lube oil N46 and N22, Chinese National Standard GB443-84).
- I After operation, first turn off the water, lightly run the drill for a few seconds, blow out the residual water drops to prevent the parts from being corroded.
- I If the drill is often used, should maintenance it regularly to ensure the inside parts cleaning. Especially pay attention to change the worn parts and lose efficient parts.

YT24 型凿岩机零配件明细表

Parts List of YT24 Rock Drill

序号 No.	零 件 号 Part No.	零件名称 Description	数量 Qty.
1	YT24-1.02	Ratchet ring 棘轮	1
2	YT24-1.03	Valve chest 阀柜	1
3	YT24-1.04	Valve 阀	1
4	YT24-1.05	Valve cover 阀盖	1
5	YT24-1.06	Valve plug 定位销	1
6	YT24-1.07	Ratchet pawl 棘轮爪	4
7	YT28-1.08a	Rifle nut 螺旋母	1
8	YT24-1.09	Rifle bar 螺旋棒	1
9	YT24-1.10a	Piston 活塞	1
10	YT24-1.11	Cylinder 油缸	1
11	YT24-1.12	Guide ring 导向套	1
12	YT24-1.13a	Muffler 消音罩	1
13	YT24-1.15	Pawl spring 塔簧	4
14	d100 ZBJ15	Hose clamp 喉箍	1
15	YT24-2.01a	Fronthead 机头	1
16	YT24-2.02	Rotary sleeve 转动套	1
17	YT24-2.03	Chuck sleeve 钎套	1
18	YT24-2.06	Steel puller bolt 钎卡螺栓	2
19	YT24-2.07a	Steel puller 钎卡	1
20	YT28-2.05	Steel puller spring 钎卡弹簧	2
21	YT28-2.12	Spring washer 弹簧垫圈	2
22	GB889 M16-ZnD	Locking nut 锁紧螺母	2
23	YT24-3.01	Elastic ring 弹性环	1
24	YT24-3.02	Through bolt 长螺杆	2
25	YT24-3.03	Throttle valve 操纵阀	1
26	YT24-3.04	Water tube 水针	1
27	YT24-3.05	Air tube 气针	1
28	YT24-3.06	Sealing gland 小密封套	2
29	YT24-3.07	Air seal 大密封套	1
30	YT24-3.08	Backhead 柄体	1
31	YT24-3.09	Through bolt nut 长螺杆螺母	2
32	YT24-3.10	Wire clip 钢丝卡环	1
33	YT24-3.12	Trigger 扳机	1
34	YT24-3.15	Directional valve 换向阀	1

35	YT24-3.16	Spring 弹簧	1
36	YT24-3.19	Wire clip 钢丝卡环	1
37	YT24-3.21	Control lever 操纵把	1
38	YT24-3.22	Detent plunger 紧固销	1
39	YT24-3.23	Water valve body 注水阀体	1
40	YT24-3.24	Wire clip 钢丝卡环	1
41	YT24-3.25a	Spring cover 簧盖	1
42	YT24-3.26	Water valve 注水阀	1
43	YT24-3.27	Left handle 左把	1
44	YT24-3.28	Right handle 右把	1
45	YT24-3.29	Rubber grip 胶把	1
46	YT24-3.30	Seal ring 密封圈	1
47	YT25-3.06	Spring 弹簧	1
48	YT25-3.09	Water tube sleeve 水针管	1
49	YT25-3.13	Rubber pad 胶垫	1
50	YT25-3.14	Air tube washer 气针垫	1
51	YT25-3.20	Spring 弹簧	1
52	YT25-3.21	Locking pin 定位销	1
53	YT25-3.24	Seal ring 环形密封圈	1
54	YT25-3.35	Washer 垫	1
55	YT28-3.11	Air pipe swivel 气管弯头	1
56	YT28-3.13	Expansion ring 涨圈	2
57	YT28-3.14	Regulating valve 调压阀	1
58	YT28-3.18	Water pipe swivel 水管弯头	1
59	25*2.4GB1235-76	O-ring O型密封圈	1
60	8*1.9GB1235-76	O-ring O型密封圈	1
61	22*2.4GB1235-76	O-ring O型密封圈	1
62	36*3.5GB1235-76	O-ring O型密封圈	1
63	GB879 8*24	Pin 园柱销	1
64	GB 93 10	Spring washer 弹簧垫圈	1
65	GB6172 M10	Nut 六角螺母	1

注：*钎尾为 25*108 时，可选用 YSP45-02.04/S25

Note: *For shank size 25*108, YSP45-02.04/S25 may be used.

FT140B 气腿零件明细表
Parts List of FT140B Air-leg

序号 No.	零件号 Part No.	零件名称 Description	数量 Qty.
1	FT140B-1a/FT140BD-1a	Outer tube 外管	1
2	FT140B-2	Mounting pad 架体垫	1
3	FT140B-3/FT140BD-3	Telescopic tube 伸缩管焊接件	1
4	FT140B-4	Guide sleeve 导向套	1
5	FT140B-5	Washer 隔垫	1
6	FT140B-6a	Pad sleeve 垫套	2
7	FT140B-7b	Rubber bowl 胶碗	2
8	FT140B-8a	Low pipe seat 下管座	1
9	FT140B-9	Sprag 顶叉焊接件	1
10	FT140B-10	Centre 顶尖	1
11	FT140B-11a	Frame body 架体	1
12	FT140B-12b	Lock ring 锁紧圈	2
13	FT140B-13	Cross arm 横臂	1
14	FT140B-14/FT14BD-14	Air pipe 气管	1
15	FT140B-17	Elastic ring 弹性圈	1
16	FT140B-18b	Dust cap 防尘密封套	1
17	FT140B-22	Rubber pad 气管胶垫	1
18	FT140B-23	Locking nut 锁紧螺母	1
19	FT140B-25	Retainer 防松套	1
20	FT140B-26	Rubber pad 弹性胶垫	1
21	FT140B-27	Thrust washer 止退垫	1
22	FT140B-29	Locking nut 锁紧螺母	1
23	FT140B-19a	Lifting handle 提把	1
24	FT160BC-30	Sealing sleeve 密封套	1
25	M10*65 GB5782-86	Bol t 小六角头螺栓	2
26	26*2.4 GB1235-76	O-ring O型密封圈	2
27	30*3.1 GB1235-76	O-ring O型密封圈	3
28	GB6172 M10-ZnD	Nut 螺母	4
29	GB93 10	Spring washer 弹垫	4
30	GB93 22	Spring washer 弹垫	2
31	M10*40GB5782-86	Bol t 小六角头螺栓	2

FY200B 注油器零件明细表

Parts List of FY200B Line Oiler

序号 No.	零件号 Part No.	零件名称 Description	数量 Qty.
1	FY200B-1	Oiler body 注油器体	1
2	FY200B-2	Needle valve 油阀	1
3	FY200B-3	Casing 壳体	1
4	FY200-2	Retainer 挡圈	1
5	FY200-11	Elastic retainer 弹性挡圈	1
6	FY200A-2	Oil plug 油堵	1
7	GB879 3×24	Pin 弹性圆柱销	1
8	14×2.4	O-ring O型密封圈	2
9	22×2.4	O-ring O型密封圈	1
10	35×3.1	O-ring O型密封圈	1
11	52×3	O-ring O型密封圈	1
12	19Q/LB3 *	Wing nut 蝶形螺母	1
13	19Q/LB4 *	Air-connector 锥形气管接头	1
14	19Q/LB14	Pipe connector 管接套	1

注：*供出口配带的件。Note: * for export.

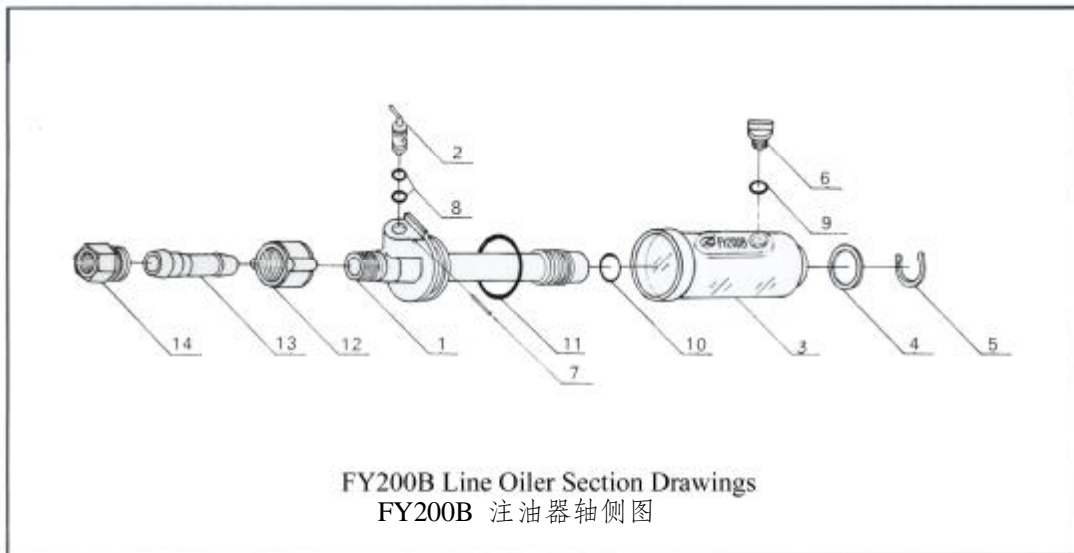

YT24 Rock Drill Section Drawing

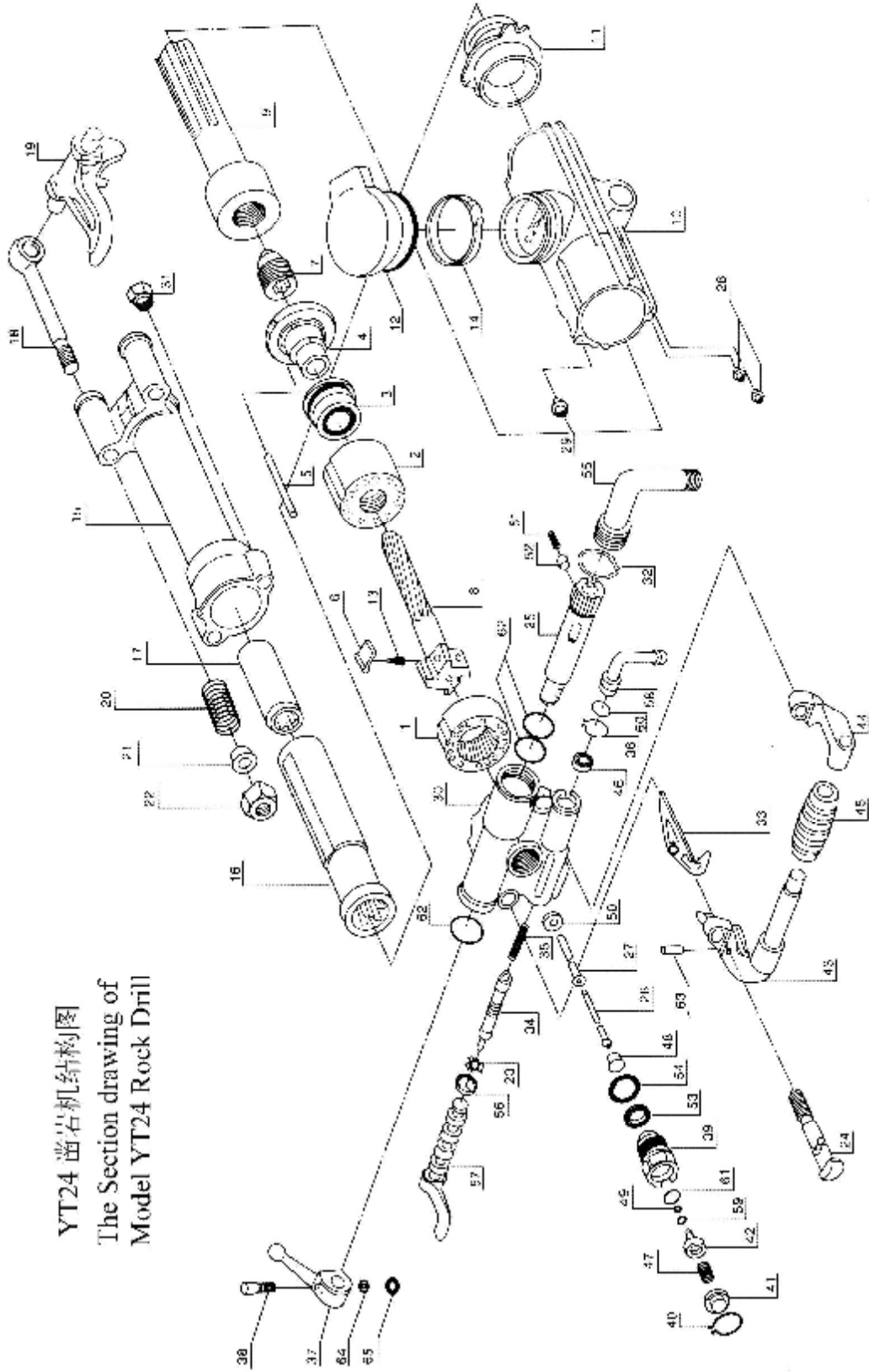

YT24 凿岩机结构图
The Section drawing of
Model YT24 Rock Drill

FT140B、FT140BD 气腿结构图
 The Section drawing of
 Model FT140B & FT140BD Air-leg

